

TRIM CUTTER

Model 3B

For more information about this model, see Bulletin 991.



SIMPLE • SAFE • CONVENIENT • ECONOMICAL

Top Performance

The 3B trim cutter offers proven BloApCo design with new, innovative maintenance and operating features to achieve higher performance and economy. Driven by a 3/4-hp electric motor, the 3B efficiently impact-cuts light paper, light SBS, and chipboard from 3 to 20 mil thick. Wear-resistant HCHC and T-15 knives handle plastic film, pressure-sensitive stock and light paper. One cutter can handle multiple ribbons of trim, depending on weight and thickness. The cut trim is reduced for pneumatic conveying, baling, disposal or recycling.

Precise Operation

Cutting with one stationary bed knife and two rotating knives, the 3B makes two cuts per revolution at speeds from 500 to 2,000 rpm. The unit passes 1,000 cfm of air at a static pressure loss of 1.5" wg at air velocities of 5,000 fpm. Adjustment screws in the rotor make the knives individually adjustable: knife clearance is easy to set, and the blades are easily removed for sharpening. Final "in-body" rotor grinding is not required. Open rotor design allows fast, free flow of cut material through the cutter housing.

Easy Installation

Installation of a 3B trim cutter is quick and simple: The cutter is shipped completely assembled and ready to run. Multiple mounting and inlet possibilities add to the 3B's adaptability and versatility. Trim pick up ducts are connected to the flanged cutter inlet, while the flanged outlet is connected to the duct that leads to the main scrap line. Excellent performance, easier maintenance, and longer life make the 3B exceptionally cost-effective.

CAPABILITIES

Materials

Light paper, light SBS and chipboard

Trim Width max

3" (75 mm)

Caliper Range

3 mil to 20 mil
0.00300" to 0.02000"
0.0762 mm to 0.508 mm

Air Capacity

1,000 cfm 1,700 m³/hr

Static Pressure Loss

1.5" wg. @ 5,000 fpm air velocity

Drive

V-Belt

Cutting Action

Impact

Rotor Speed

500 to 2,000 rpm

Weight

145 lbs. (66kg) with motor

Dimensions

L x W x H: 15³/₈" x 14³/₁₆" x 26³/₄"
(390.5 mm x 360.4 mm x 679.5 mm)

FEATURES

- Rotor-mounted knife-adjustment screws; fast and easy setups
- Knives easily removed for sharpening or replacement
- Multiple knives: HCHC and Carbide
- Ball-bearing construction
- Open-rotor design for easy passage of air and material
- Flanged inlet, slip-fit outlet
- 3/4-hp 3/60/460 volt TEFC motor standard

OPTIONS

- Oil mist unit
- Safety disconnect switch
- Tandem rail mounting with BloApCo material handling fans

Dimensions

Model 3B

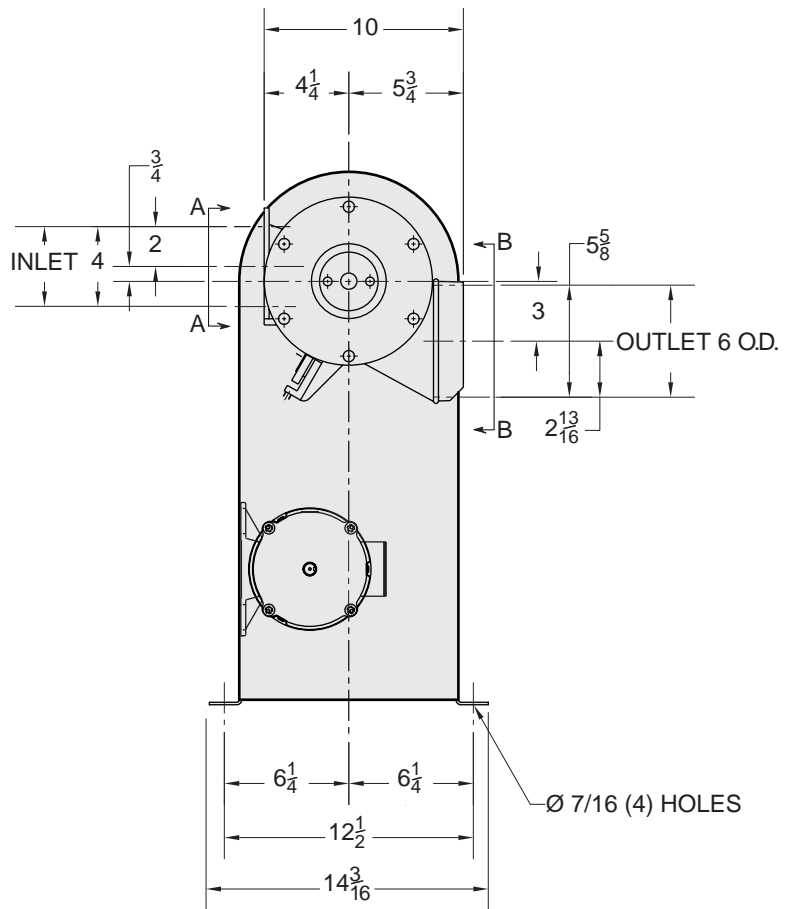
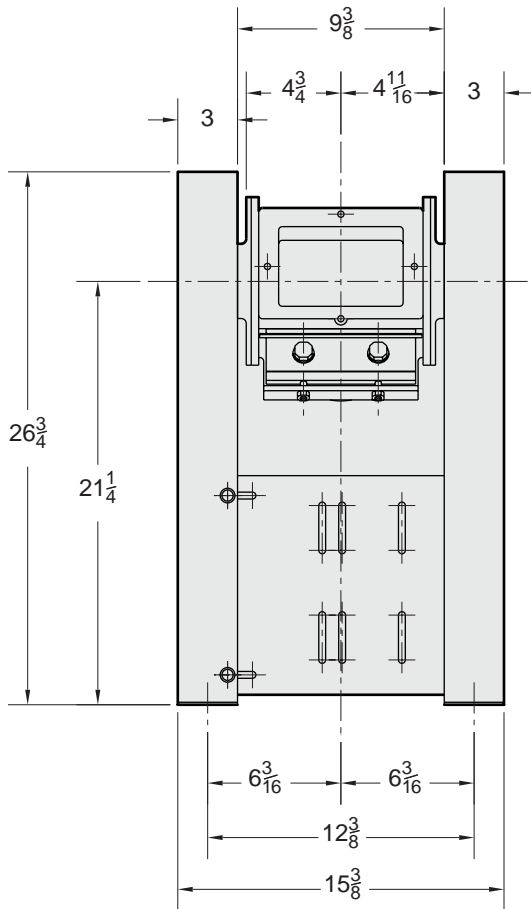

NOTE: STAND LEG NOT SHOWN ON THIS VIEW SO THAT THE TRIM CUTTER IS VISIBLE.

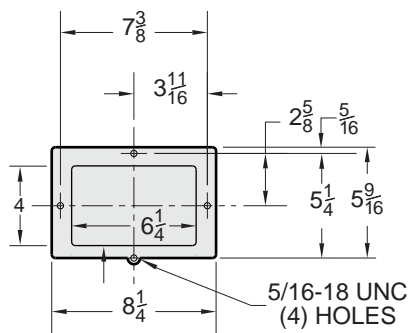

VIEW "A-A"
INLET

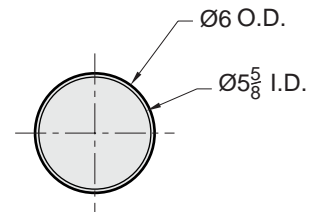

VIEW "B-B"
OUTLET

For more information about this model, see Bulletin 991.



BloApCo
Blower Application Company

N114 W 19125 Clinton Drive • P.O. Box 279 • Germantown, WI 53022-0279 • 800.959.0880 • 262.255.5580 • FAX: 262.255.3446 • bac@bloapco.com • bloapco.com