

TRIM CUTTER

Model 5SC

For more information about this model, see Bulletin 991 and Application Reports 22 & 23.

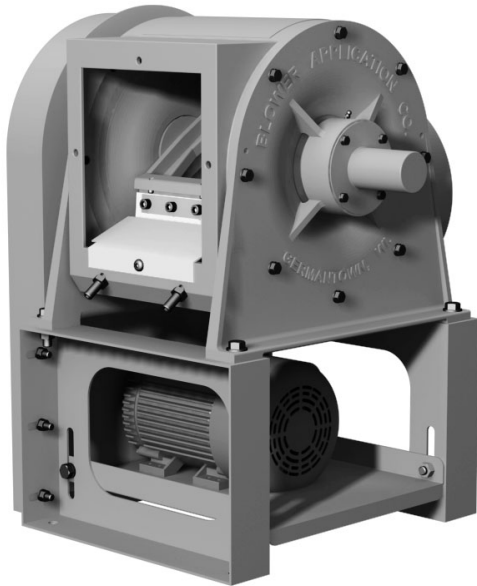

SHEAR-CUT ACTION FOR GREATER CAPACITY, REDUCED NOISE

MAINTAINS CUTTING EDGE WITHOUT IN-PLACE CYLINDRICAL GRINDING

Top Performance

The 5SC trim cutter offers proven BloApCo design with new, innovative maintenance and operating features to achieve higher performance and economy. Driven by a 2-hp electric motor, the 5SC shear-cuts everything from paper to poly films to metal, foil down to 3 mil thick. Varied knife profiles make short work of corrugated and heavy-fiber laminated trim up to 8½" wide. Wear-resistant HCHC, NEOR and carbide knives can be mated with slitting equipment and reduce multiple ribbons of trim, depending on weight and thickness, for pneumatic conveying, baling, disposal or recycling.

Precise Operation

Cutting with one stationary bed knife and two rotating knives, the 5SC makes two cuts per revolution at speeds from 500 to 2,000 rpm and passes 3,000 cfm of air at a static pressure loss of 1.5" wg at air velocities of 5,000 fpm. Rotor-mounted set screws make the knives individually and easily adjustable for maximum precision, and easy to remove for sharpening with no need for "in-body" rotor grinding. Precision tapered roller bearings eliminate end play and runout problems, keeping clearances precise longer. Open rotor design allows fast, free flow of cut material through the cutter housing.

Easy Installation

Installation of a 5SC trim cutter is quick and simple: The cutter is factory-tested, tailored to your application, and shipped completely assembled and ready to run.

CAPABILITIES

Materials

Paper, film, heavy corrugated and fiber board, light metal foils

Trim Width max

8½" (216 mm)

Caliper Range

3 mil to 250 mil
0.00300" to 0.25000"
0.0762 mm to 6.350 mm

Air Capacity

3,000 cfm 5,100 m³/hr

Static Pressure Loss

1.5" wg. @ 5,000 fpm air velocity

Drive

V-Belt or Direct Drive

Cutting Action

Shear

Rotor speed

500 to 2,000 rpm

Weight

355 lbs. (161kg) with motor

Dimensions

L x W x H: 22⁵/₈" x 18½" x 28³/₄"
(574.7 mm x 469.9 mm x 730.3 mm)

FEATURES

- Rotor-mounted knife-adjustment screws for fast, easy setups
- Multiple knives: HCHC, NEOR, NEOR metal grind, carbide-edge
- Class "O" tapered roller bearings eliminate endplay and runout
- Rotor shaft supported by tapered roller bearings maintains rotor stability for long life
- Open-rotor design facilitates passage of air and material
- Multiple mounting and drive arrangements
- Multiple flanged inlet, slip-fit outlet positions
- 2 HP 3/60/460-volt TEFC motor is standard

OPTIONS

- Oil mist unit
- Flywheel
- Safety disconnect switch
- Tandem rail mounting with BloApCo material-handling fan

Dimensions

Model 5SC

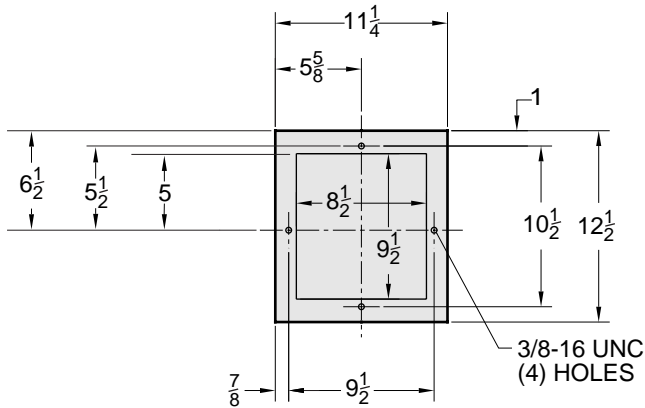
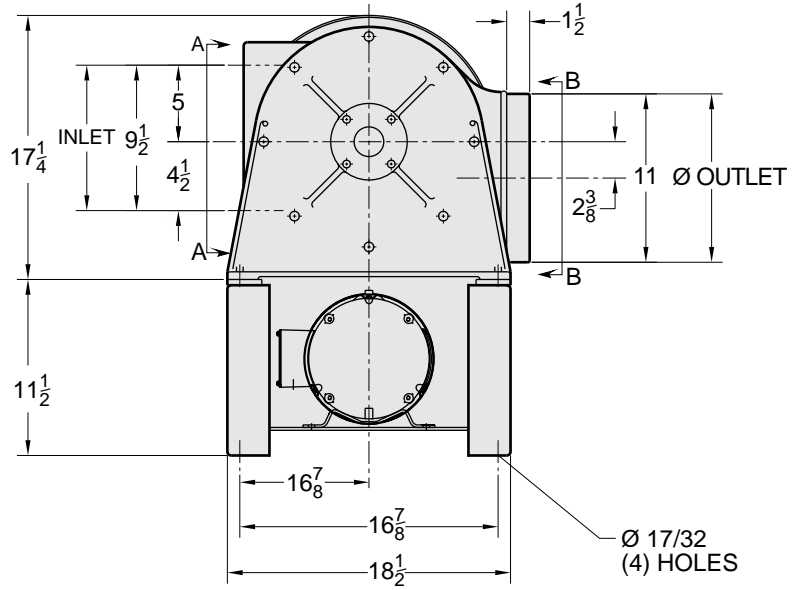
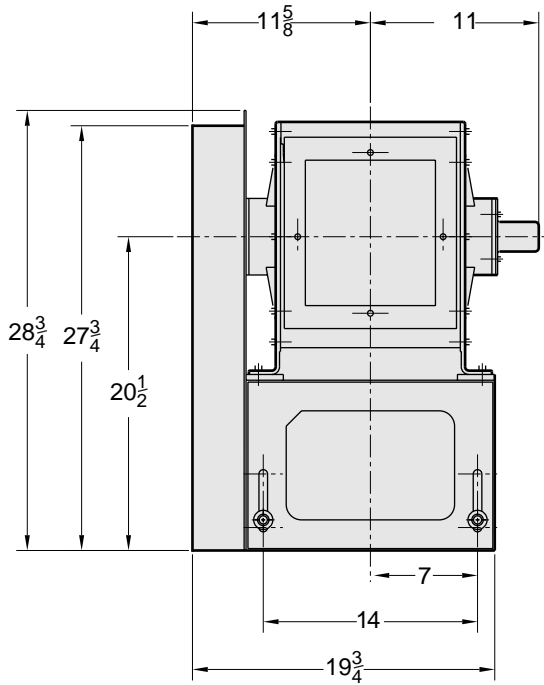

VIEW "A-A"
INLET

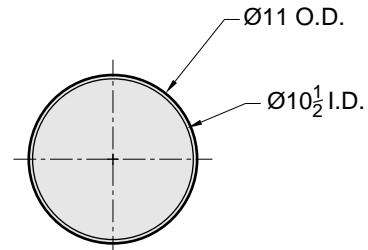

VIEW "B-B"
OUTLET

For more information about this model, see Bulletin 991 and Application Reports 22 & 23.



BloApCo
Blower Application Company

N114 W 19125 Clinton Drive • P.O. Box 279 • Germantown, WI 53022-0279 • 800.959.0880 • 262.255.5580 • FAX: 262.255.3446 • bac@bloapco.com • bloapco.com